

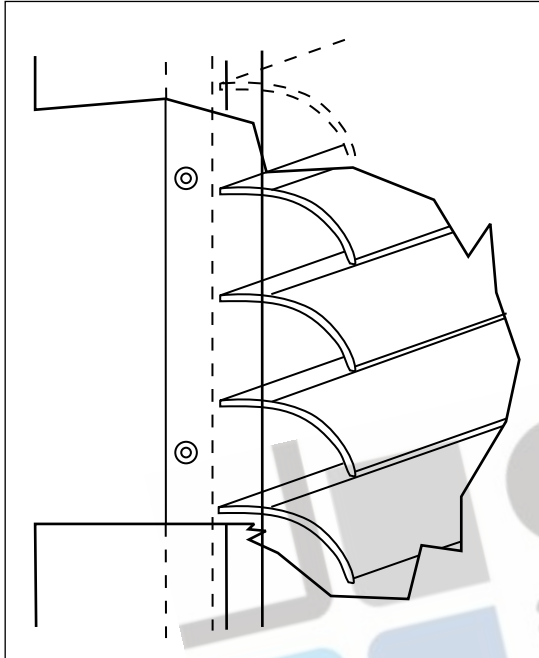

GRILLES

Return Air

■ RA



- These grilles feature light weight extruded aluminium with or without damper attached.
- The standard grilles are available with fixed horizontal blades spaced at 21mm apart.

GENERAL SPECIFICATIONS

- Different spacing can be offered as a special request.
- The frame is constructed of 1.3mm thickness extruded aluminium with curved fins of extruded aluminium of 1.2 to 1.6mm thickness.
- The damper is constructed from extruded aluminium blades and frame.
- Grille can be furnished with powder coated white finish preceded by a five stage preparation process of cleaning, phosphatising and drying.
- Other colours are available on request.
- Grilles can also be supplied as natural anodised.
- For outside weatherproof applications the Return Air Ribbed Blade (RARB) can be offered. This type is particularly suited to grilles for console air conditioners.

GRILLES

Return Air



■ RA

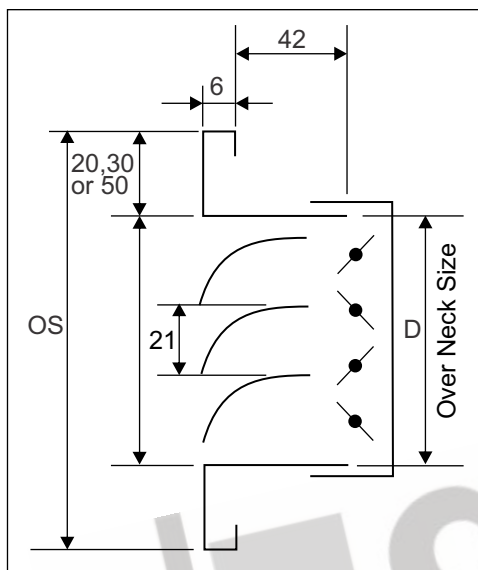

TYPE RA: (45deg. Deflection): Return Air Grille manufactured of extruded type anodising grade aluminium with fixed curved blade profile giving low see through characteristics. This grille may be mounted vertically or horizontally.

Optical Accessories

- OBD = Opposed Blade Damper
- PC = Punched counter sunk holes
- CF = Concealed Fixing
- FS = Rear fixing straps

Frame Options

- 30mm Standard
- 20mm
- 50mm

Finish Options

- NA = Natural Anodised
- EPC = Epoxy Powder Coating

Blade Spacings

- 13mm
- 21mm Standard
- 26 mm

Ordering Procedure: Example

Ref	Qty	Size (L x H)	Type	Access	Frame	Finish	Special Instructions
1	7	500 x 200	DD	OBD	30	NA	CF

Note:

- (1) Dimensions given are for opening size into which grille will fit (i.e Normal Duct Size)
- (2) If code "OS" is entered under SPECIAL INSTRUCTIONS, then dimensions given are over flange.



RA Performance Data

