



AIR VALVES

Smart Air Disc

DVP

DVP Smart can be used effectively for exhaust and supply of air in damp areas such as toilets, bathrooms, kitchen as well as industrial areas and offices.

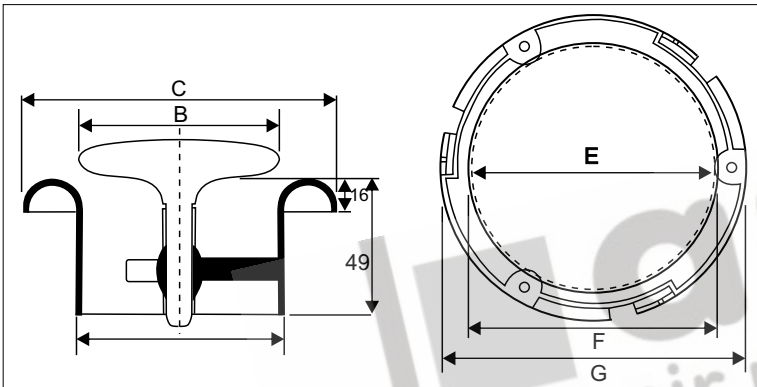

DVP P Smart	ØB	ØC	ØD	ØE	ØF	ØG
Ø100	96	152	99	116	120	146
Ø125	121	177	124	141	145	171
Ø150	146	202	149	166	170	196

- Energy efficient.
- Very low pressure loss values complying with ASHRAE 70 standards.
- No corrosion with all parts manufactured from ABS plastic.
- Fully-airtight product with minimum air leakage offer better indoor air quality with mould control.
- Conserves the flow regime due to Smart design.
- Quick mounting with compact and smart components.

